

MULTIHEAD WEIGHER 10-HEAD AW-M10A



AW-M10A1

APPLICATION

Confectionery, bakery, biscuits, cereals, dried fruit, seeds, snacks, chips, flakes, nuts, pet foods, plastic parts, fasteners, etc. Virtually weighs any dry products of varying shapes and sizes.

MAIN FEATURES

- Staggered dumping avoids blockages of the transfer tube
- Multiple languages in a single touch-screen display
- All surfaces in contact with the product are stainless steel
- All parts are enclosed to prevent product build-up
- Wash-down and dust-proof construction
- Touch-screen backlighting is adjustable
- Speed adjustment of hopper movement by stepper motor
- No air consumption
- 99 preset programs available

SPECIFICATIONS

MODEL	AW-M10A1	AW-M14A1
Maximum Weight	3,000g	
Accuracy	±0.1g to 2g	
Maximum Rate (Weighments per Minute)	70 wpm	120 wpm
Weigh Bucket Volume	1.3 Litres	1.3 Litres
Power Requirements	220VAC 50Hz, 1.5kW	220VAC 50Hz, 2kW
Net Weight	300kg	350kg
Gross Weight	390kg	430kg
Controller/Display	7" Touch-Screen	

DIMENSIONS

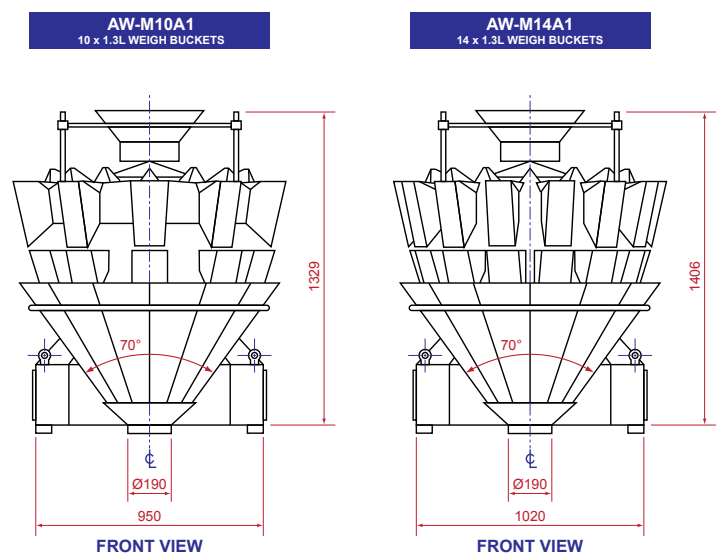

by ACCUPAK