

# MULTIHEAD WEIGHER 14-HEAD AW-M10C

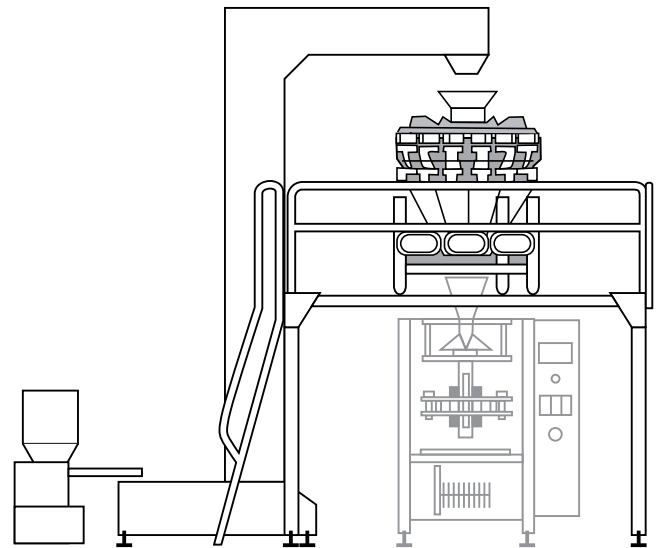

**EASY SYSTEM INTEGRATION**

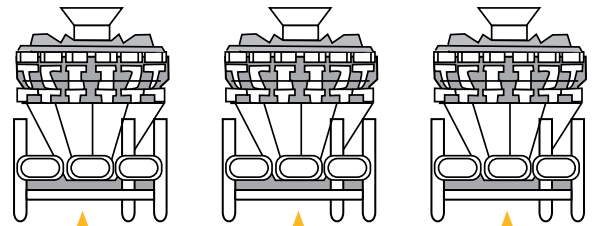

## APPLICATION

Ideal for weighing fresh and frozen vegetables due to its Stainless Steel grade 304 construction.

## SPECIFICATIONS

Weighing Range (per single dump)	Up to 2,000g
Accuracy	0.1g to 1.5g
Weighing Hopper Volume	1.7 Litres
Volume per Dump	4.5 Litres
Maximum Speed	150 Weighings per Minute

## MAIN FEATURES

- Minimal product clumping due to dense dimpling on product surfaces
- All parts are continuously welded and all corners are rounded
- All parts in contact with the product can be easily removed, making it easy for cleaning and preventing bacteria growth
- The required level of product is controlled by weight, rather the traditional photocell, providing a constant distribution of product flow
- All weighing heads are controlled by a stepper motor
- Staggered dump delay facility to avoid blockages in the forming tube



by **ACCUPAK**